



## SOFTSTART USER'S MANUAL

ZJR1 SERIES



**ZIRI ELECTRICAL TECHNOLOGY CO.,LTD**

# Foreword

- Thank you for your purchase of ZJR1 series of motor softstarter produced by Ziri Electrical Technology Co.,Ltd. (hereinafter referred to as ZIRI Company).
- This manual introduces the installation, operation, function setting, trouble shooting and etc. of ZJR1 motorsoft starter.
- Incorrect installation or use may result in damage or other accidents.
- Do read all instructions in detail before installing, and follow this manual strictly during installing, wiring and operating.
- Please keep this manual handy for quick reference in the future.
- If there are any doubts or questions, please contact the Technical Service Center of ZIRI Company.

# Table of Contents

Chapter 1 Introduction to the Product.....	1
1.1 Safety Instructions.....	1
1.2 Product Inspection upon Arrival.....	2
1.3 Demonstration of the Specifications Label and Model...2	
1.4 Outline of the Product.....	3
1.5 Models and Specifications.....	4
1.6 Technical Indications.....	5
Chapter 2 Installation and Wiring.....	6
2.1 Operating Conditions.....	6
2.2 Installation.....	6
2.3 Wiring.....	7-12
2.4 Selection of Peripheral Appliances.....	13
Chapter 3 Operation Panel and Display.....	14
3.1 Operation Panel Instructions.....	14
3.2 Panel Operation.....	14-15
3.3 Panel Display Instructions.....	16
Chapter 4 Operation.....	17
4.1 Inspection before Operation.....	17
4.2 Operation.....	17
Chapter 5 Description of Function Parameters.....	18
5.1 Schedule of Function Parameters.....	18
5.2 Detailed Description of Function Parameters.....	19-26
Chapter 6 Trouble Protection & Treatment.....	27
6.1 Schedule of Protection Operating.....	27
6.2 Trouble Diagnosis and Troubleshooting.....	28
Chapter 7 Structure and Sizes.....	29-30
Chapter 8 Quality Warranty.....	31
Appendix.....	32

# Chapter 1

# Introduction to Product

## 1.1 Safety Instructions

- ①The installation and wiring of motor soft starter should be operated only by professional technicians who should read this manual in detail before installing and wiring.
- ②Do not perform wiring while the motor soft starter is POWER ON. Be sure to perform this step only after the power is disconnected. Otherwise, there is the danger of electric shock.
- ③Be sure the motor chosen should be matched with the motor soft starter. Do follow this manual while perform installing and wiring.
- ④While wiring, the three-phase input power supply should be connected to the terminals R, S and T. The output wire of the motor should be connected to the terminals U, V and W. Otherwise, it may cause severe damage to the motor soft starter.
- ⑤Do not install any capacitor between the output terminals U, V and W and the motor. Otherwise, it may cause damage to the motor soft starter.
- ⑥The electronic elements inside the motor soft starter are very sensitive to static. Do not touch the appliances on the circuit board by hand before anti-static measures are taken.
- ⑦The ground terminal ( $\text{≐}$  G) should be properly, solidly and separately grounded.
- ⑧Once the motor soft starter is installed, please cover pigtails in the input and output ports with insulated sheath or tape.
- ⑨When the motor soft starter is under remote control, do lock the keyboard control to avoid accident due to error operation.
- ⑩Do cut off the power supply when the motor starter is in maintenance to guarantee safety.

# Chapter 1 Introduction to Product

## 1.2 Inspection upon Arrival

This product is guaranteed a high level of quality with strict outgoing inspection, crushproof and shockproof packaging. But there is the possibility of damage in transit by carelessness. So it is necessary to unpack the package upon receipt of the product and perform the following steps:

- ①Check the motor soft starter whether there is any damage caused during transit.
- ②Check the specifications label of the motor soft starter and make sure it matches the product part number you've ordered.
- ③Check whether the items in the package are in readiness or not, which include 1 motor soft starter, 1 user manual and 1 conformity certificate. In case there is any problem with the above-mentioned contents, damage or deficiency, please contact your dealer or Ziri Company immediately.

## 1.3 Demonstration of the Specifications Label and Model

### 1.3.1 Demonstration of the Specifications Label

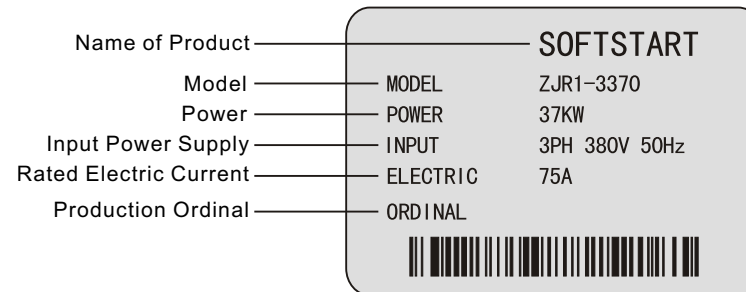

### 1.3.2 Demonstration of the Model

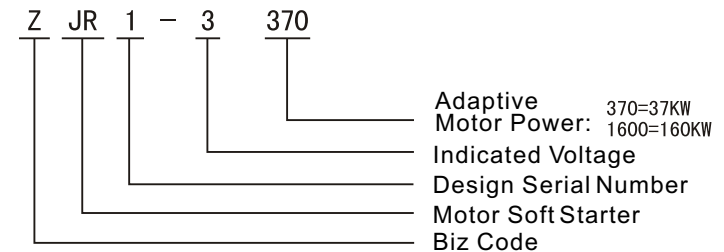

## Chapter 1 Introduction to Product

### 1.4 Outline of the Product

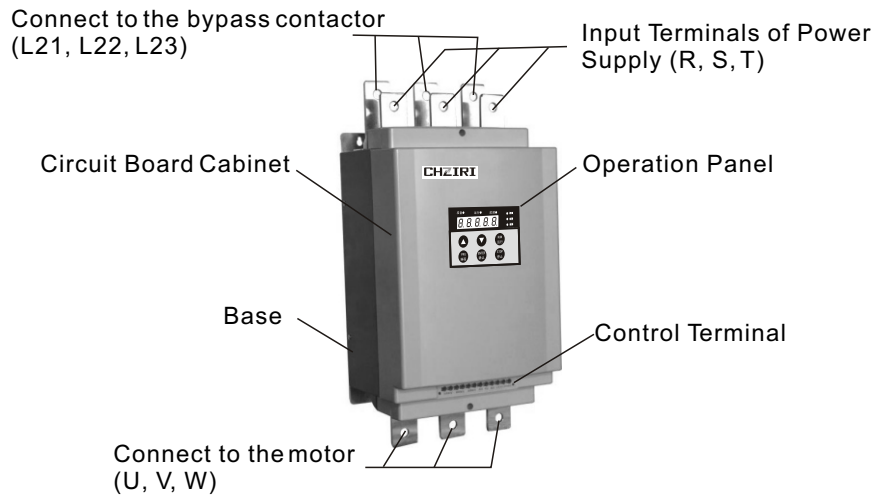
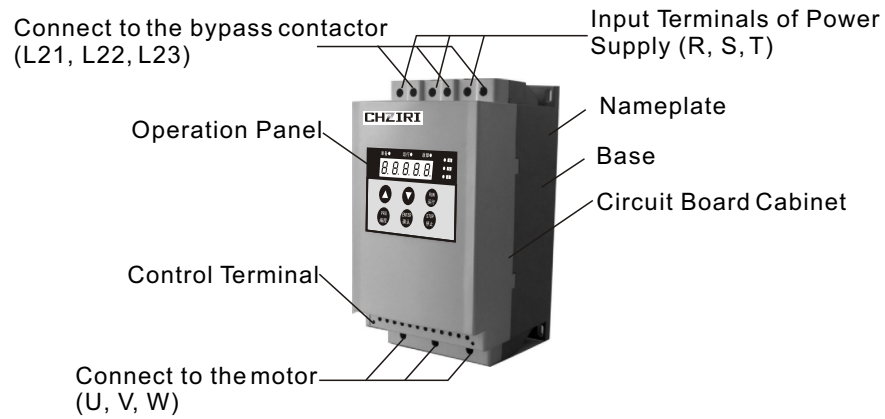

## Chapter 1 Introduction to Product

### 1.5 Models and Specifications

#### Schedule of Models & Specifications

Product Model	Max Adaptive Motor Power(KW)	Input Voltage (V)	Rated Current (A)	Weight of Type Z (Kg)
ZJR1-3055	5.5	380	11	3.5
ZJR1-3075	7.5	380	15	3.5
ZJR1-3110	11	380	22	3.5
ZJR1-3150	15	380	30	3.5
ZJR1-3185	18.5	380	37	3.5
ZJR1-3220	22	380	43	3.5
ZJR1-3300	30	380	60	3.5
ZJR1-3370	37	380	75	3.5
ZJR1-3450	45	380	90	3.5
ZJR1-3550	55	380	110	3.5
ZJR1-3750	75	380	150	25
ZJR1-3900	90	380	180	25
ZJR1-31100	110	380	220	25
ZJR1-31320	132	380	264	25
ZJR1-31600	160	380	320	25
ZJR1-32000	200	380	400	25
ZJR1-32500	250	380	500	35
ZJR1-32800	280	380	560	35
ZJR1-33150	315	380	630	35
ZJR1-34000	400	380	800	40
ZJR1-35000	500	380	1000	45

## Chapter 1 Introduction to Product

### 1.6 Technical Indications

Item		Item Description
Input Power Supply	Input Voltage	Three-phase 380V-15% ~ 415+10%
	Frequency	50/60Hz
Adaptive Motor	Squirrel-cage three-phase asynchronous motor	
Starting Times	It is recommended not to exceed 20 times per hour	
Control Modes	1) Operation panel control; 2) Operation panel + external control; 3) External control; 4) External control + COM control; 5) Operation panel + external + COM control; 6) Operation panel + COM control; 7) COM control; 8) No start or stop operation.	
Start Modes	1) Current-limiting start; 2) Voltage ramp start; 3) Kick start + current-limiting start; 4) Kick start + voltage ramp start; 5) Current ramp start; 6) Voltage current-limiting double closed-loop start.	
Stop Modes	1) Soft stop; 2) Free stop.	
Protective Functions	1) Open loop protection for external instantaneous stop terminals; 2) Over-heat protection for soft starter; 3) Protection for too long starting time; 4) Input open phase protection; 5) Output open-phase protection; 6) Unbalanced three-phase protection; 7) starting overcurrent protection; 8) Running overload protection; 9) Undervoltage protection for power voltage; 10) Overvoltage protection for power voltage; 11) Protection for fault parameter setting; 12) Load short circuit protection; 13) Autorestart or incorrect wiring protection; 14) Incorrect wiring protection of external control stop terminals.	
Ambient	Place to be used	Indoor location with good ventilation free from corrosive gas and conductive dust.
	Altitude	Below 1,000M. Derating should be performed before use if the altitude is higher than 1,000M.
	Ambient Temperature	-10~+40℃
	Ambient Humidity	≤90%RH without dew condensation.
	Vibration	<0.5G
Structure	Protection Class	IP20
	Cooling Pattern	Natural wind cooling.

## Chapter 2

## Installation and Wiring

### 2.1 Operating Conditions

Use the motor soft starter in the following environmental conditions:

- ① Altitude: Maximum 1000m above sea level. Derating should be performed before use if the altitude is higher than 1,000M.
- ② Ambient Temperature: -10~+40℃
- ③ Ambient Humidity: =90% RH (Non-condensing)
- ④ Place to be used: Indoor places free from direct exposure to sunlight, dust, corrosive gas, flammable gas, oil mist, steam, drip and salt.
- ⑤ Vibration: <0.5G
- ⑥ Starting Times: =20 times per hour.

### 2.2 Installation

- ① The motor soft starter shall be installed vertically. DO NOT turn upside down, lay diagonally or horizontally while installing. Be sure the base is fixed solidly and evenly.
- ② To get better cooling effect and for the convenience of maintenance, the motor soft starter shall be installed with enough space left, refer to the figure below.

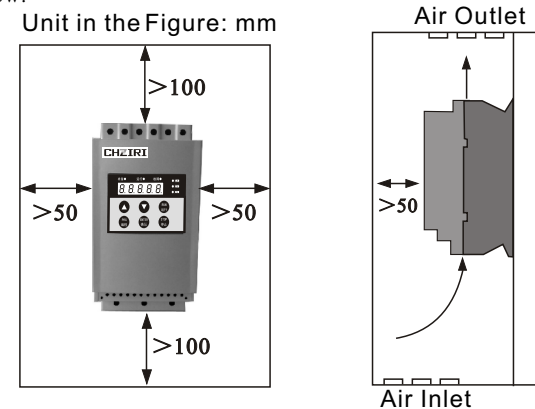

2.3 Wiring

The wiring of motor soft starter should be operated only by professionals experienced in high and low voltage electric circuit and should read this manual in detail before wiring.

2.3.1 Standard Wiring Diagram

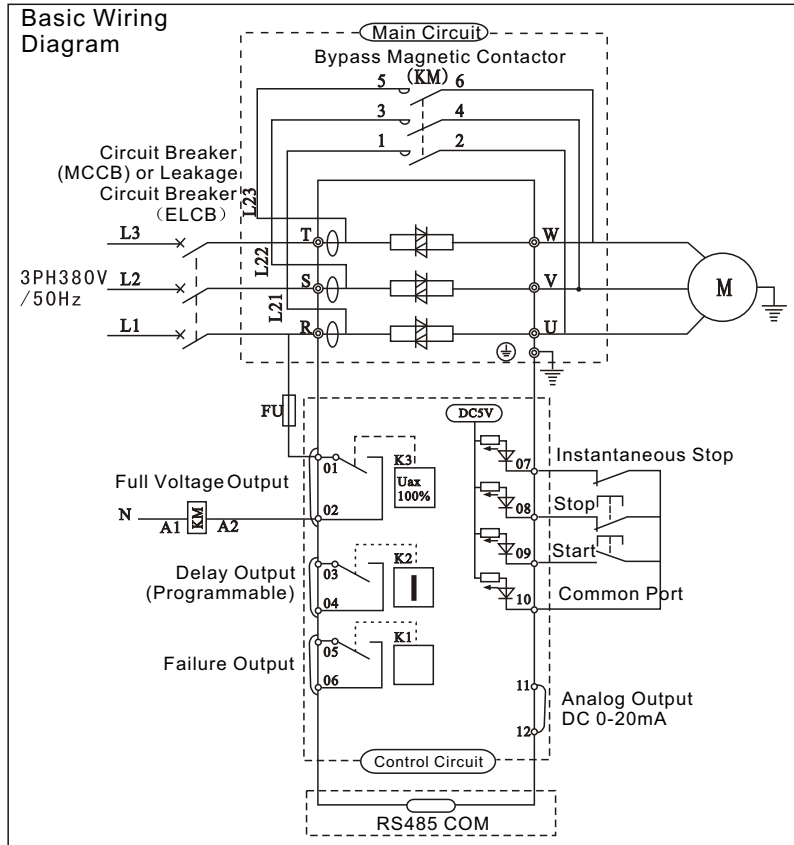

2.3.2 Description of Main Circuit Terminals

Terminal Mark	Terminal Name	Functional Description
R、S、T	Main Circuit Input Terminal	Connect to three-phase input power supply.
U、V、W	Main Circuit Output Terminal	Connect to three-phase electric motor.
L21、L22、L23	Bypass Connection	Connect to bypass contactor
⊥ G	Ground Terminal	Soft starter cabinet ground terminal

1) Input Terminals (R, S, T)

- ① Three-phase input power supply should be connected to the input terminals R, S and T of the motor soft starter after it goes through the circuit breaker. Three-phase power supply does not differ on phase sequence and can be arbitrarily connected.
- ② While wiring, DO connect three-phase input power supply to the terminals R, S and T. Otherwise, it may result in severe damage to the motor soft starter.
- ③ It is recommended not to shut down the machine by disconnecting the main circuit power supply or install an electromagnetic contactor between the input terminals R, S, T and the power supply to run or stop the motor soft starter. Do select RUN or STOP keys on the operation panel or external control terminals to run or stop the motor soft starter.

2) Output Terminals (U, V, W)

- ① The output terminals U, V and W should be connected to the three-phase motor. If the motor counterrotates (reverses), just change arbitrarily two phases of U, V and W.
- ② Do not install a capacitor or surge absorber between the output terminals U, V, W and the three-phase motor. Otherwise, it may result in failure of the motor soft starter or damage to the devices.
- ③ Too long connecting line between the motor and the motor soft starter may result in overcurrent trip, increase of cutoff current, low accuracy of current display of the motor soft starter. So, it is suggested to use a line not exceeding 50m.

3) Bypass Connection (L21, L22, L23)

The bypass connection terminals L21, L22 and L23 should be connected to the electromagnetic contactor. No wrong connection or incorrect phase sequence! When the starting of the soft starter is finished, the main loop power device (SCR) will log out and the bypass electromagnetic contactor will run simultaneously. At this time, the motor is brought into normal service.

4) Ground Terminal (⊥ G)

The ground terminal of motor soft starter should be properly connected to the ground to avoid electric shock or fire. The ground wire can not share a ground point with any other strong current load. They must be connected respectively, and the ground wire is the shorter the better

2.3.3 Main Circuit Connection Diagram

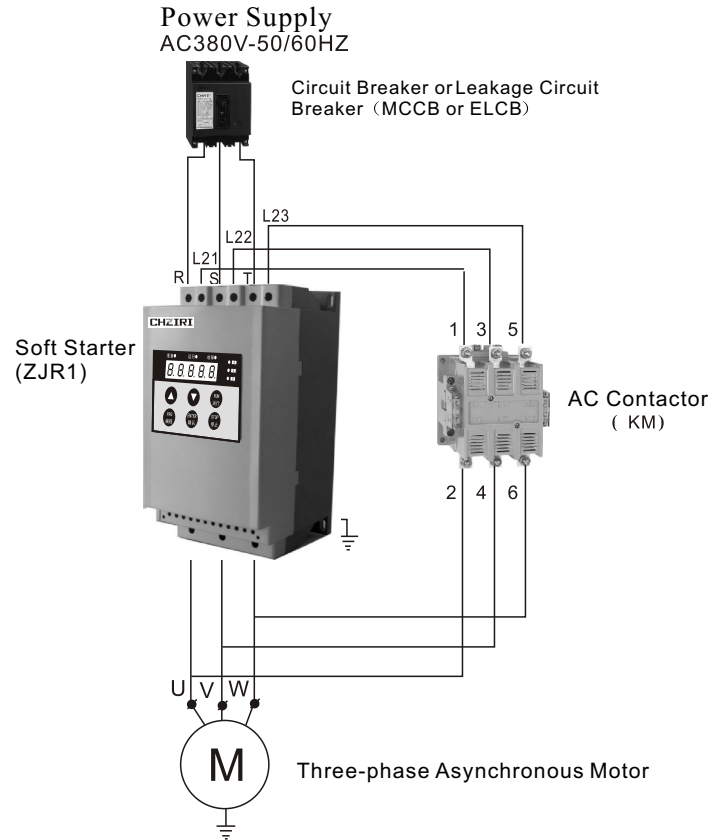

2.3.4 Description of Control Circuit Terminals

1) Cautions for Control Circuit Wiring:

① The connecting wire of the control circuit shall be shielded wire or twisted pair wire, which must be wired separately from the main circuit and the power circuit. If the connecting wire of the control circuit must crosscut the main circuit, they shall intersect at an angle of 90°.

- ② The length of the wire shall be as short as possible (not exceed 30m generally) because the control circuit is easily influenced by external interference.
- ③ The recommended wire size of the control circuit connecting wire is 0.75mm<sup>2</sup>.
- ④ When external terminals are selected to give control over start and stop functions of the soft starter, please set the code P9 to "External Control Enabled".
- ⑤ If there is a request for non-local control, the two-wire control mode is suggested.

2) Diagram of Control Terminals

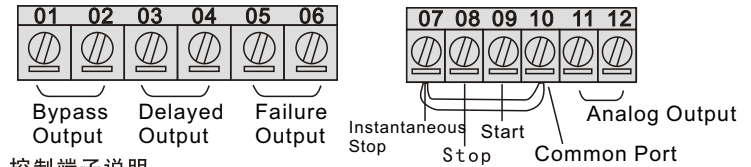

(三) 控制端子说明

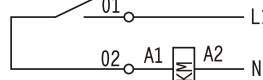
Terminal Mark	Terminal Name	Functional Description
01, 02	Bypass Output	Switch on 01 and 02 after soft starter is completely started to control bypass contactor. 
03, 04	Operation Output (Delayed)	03 and 04 indicate programmable relay output whose functions are set by the code Pb. If they are set to be the make contacts (normally open) and output voltage of the soft starter is enabled to start the motor, then 03, 04 will be switched on. (Contact capacity: AC 250V/3A)
05, 06	Failure Output	05, 06 indicate programmable failure relay output which will be closed (switched on) if there is failure of the soft starter or power, and open (switched off) when energized.
07	Instantaneous Stop Input	If 07 is disconnected from 10 or connected to the break contact (normally closed) of any other protectors, the motor will stop immediately.
08	Soft Stop Input	When 08 and 10 are switched off, the motor will perform decelerated soft stop or free stop.
09	Start Input	Close 09 and 10, the motor begins starting and running.
10	Common Port	10 indicates common terminal of the contact input signal.
11, 12	Analog Output	11 and 12 indicate AC (0~20mA) analog output used to monitor operating current of the motor. When the value is 20mA, which means the output current is 4 times as nominal current capacity of the motor, an external DC ammeter (0~20mA) can be connected, and the maximum value of output load resistance will be 300Ω.
DB9	RS485 COM	RS485 COM input/output terminal, used to connect multiple soft starters.

2.3.5 External Control Wiring Modes

① Three-phase Control Mode

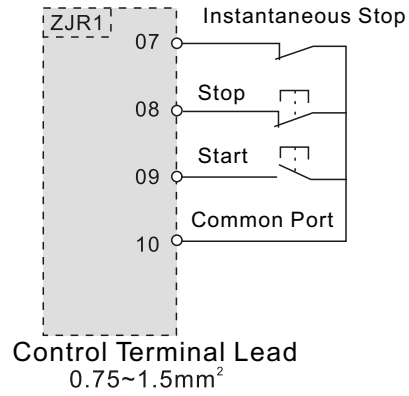

② Two-wire Control Mode

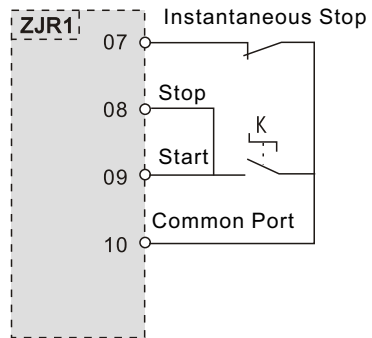

Switch K on, motor starts; switch K off, motor stops.

2.3.6 Relay & Non-local Control Wiring Diagram

Relay Control Mode

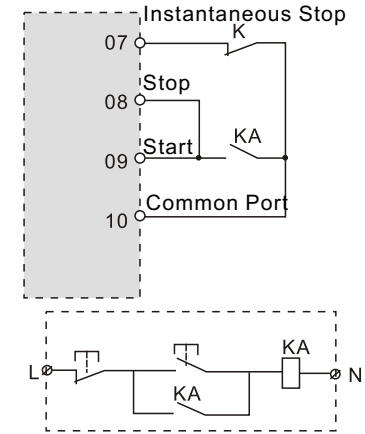

Relay Control Mode

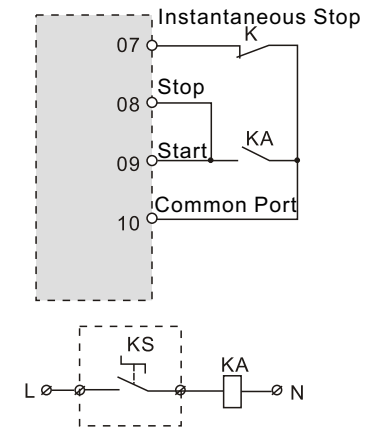

K is connected to the break contact (normally close) of a protector, i.e., a thermal protector. The factory default setting of K is shorted.

## Chapter 2 Installation and Wiring

### 2.4 Selection List of Peripheral Appliances

Option list of the motor soft starter peripheral breakers, electromagnetic contactors and cables, shown as below:

Soft Starter Models	Motor Power(KW)	Motor Rated Current (A)	Breaker Specifications (A)	Electromagnetic contactor Specifications (A)	Cable Sizes (mm <sup>2</sup> )
ZJR1-3055	5.5	11	16	16	4
ZJR1-3075	7.5	15	20	16	6
ZJR1-3110	11	22	32	25	6
ZJR1-3150	15	30	40	40	10
ZJR1-3185	18.5	37	50	40	16
ZJR1-3220	22	44	63	63	16
ZJR1-3300	30	60	80	63	25
ZJR1-3370	37	75	100	100	25
ZJR1-3450	45	90	125	100	25
ZJR1-3550	55	110	160	160	35
ZJR1-3750	75	150	180	160	50
ZJR1-3900	90	180	225	250	70
ZJR1-31100	110	220	315	250	70
ZJR1-31320	132	264	315	400	50X2
ZJR1-31600	160	370	350	400	50X2
ZJR1-32000	200	400	500	400	70X2
ZJR1-32500	250	500	630	630	95X2
ZJR1-32800	280	560	560	630	95X2
ZJR1-33150	315	630	700	630	95X2
ZJR1-34000	400	800	800	630	120X2
ZJR1-35000	500	1000	1000	1000	120X2

Options in the above table are for reference only.

## Chapter 3 Operation Panel

### 3.1 Description of Operation Panel

#### 1) Outline Drawing of Operation Panel

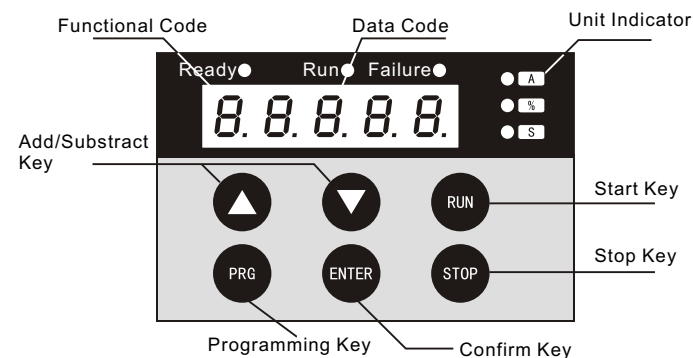

#### ② Operation Panel Key Set Description

Symbols	Key Set Name	Functional Description
	Run Key	When "REAdy" is displayed, press this key to begin starting the machine, and the starting state "XXXX" will be displayed.
	Stop Key	1) When the machine is in normal operation, press this key to stop and "XXXX" will be displayed once the machine stops completely. 2) This key also performs the function of failure state resetting.
	Programming Key	When "REAdy" is displayed, press this key to set the manual. When "P0030" is displayed, repress this key. When ":" flashes, press ▲ ▼ to modify parameters.
	Confirm Key	1) After parameters are modified in programming, press this key to save. If there is the indication of "good" with 2 sounds, this indicates the data has been saved. Repress this key or press the stop key to exit. 2) Press this key when the machine is in operation, the voltage of input power supply will be displayed. 3) When the power is on, press this key and the parameters you've set will be restored to the factory default value.
	Add Key	1) When entering into manual setting, press this key to modify parameters. (When the colon does not flicker, this key is used to modify the functional code; when the colon flickers, this key is used to modify the data value.)
	Subtract Key	2) When the machine is in operation, press this key to keep an eye on the display of current (A), power (P) and overload heat balance (H).

● When the last decimal behind the three-figure data >999 is lightened, then "0" shall be added behind the mantissa.

● The tone beeps while pressing any of these keys. Otherwise, this action is invalid.

## Chapter 3 Operation Panel

### 3.2 Panel Operation

#### ① Parameter Modification Example

Eg. If the control mode is changed to external terminal control, just set the code P9 to 02.

Ordinal No.	Action	Display	Description
1	Power on.	<b>P.OFF</b>	Getting started.
2	Press <b>PRG</b>	<b>P0030</b>	Enter into the state of programming.
3	Press <b>▲</b> for 9 times.	<b>P9001</b>	Enter into functional selection mode of the code P9.
4	Press <b>PRG</b>	<b>P9:001</b>	The range of setting can be modified when colon flashes.
5	Press <b>▲</b> Twice.	<b>P9:002</b>	02 indicates external terminal control.
6	Press <b>ENTER</b>	<b>G.OOd</b>	The data modified has been saved. The action is escaped to the default state and "REAdy" is displayed.

Note: While pressing any of these keys, the beeper inside the soft starter will give out a beep tone.

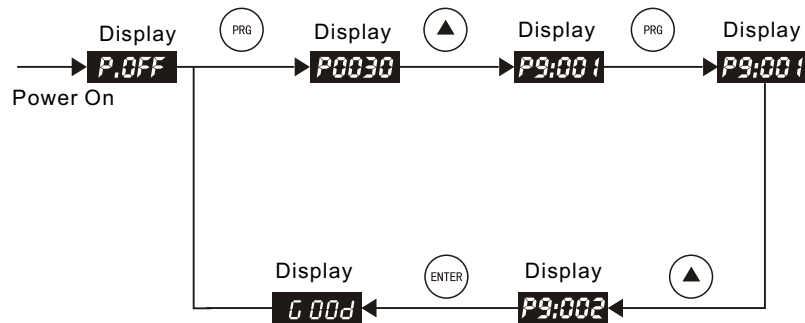

## Chapter 3 Operation Panel

### 3.3 Description of Panel Display

Codes Displayed	Description
<b>P.OFF</b>	This indicates the power is ON.
<b>REAdy</b>	This indicates the motor soft starter is getting ready and the readiness LED turns on.
<b>~X XXX</b>	This indicates the motor is in the state of getting started.
<b>~X XXX</b>	This indicates the motor is in the running state and the running indicator turns on.
<b>~X XXX</b>	This indicates the motor is in the state of soft stop.
<b>AV:380</b>	This indicates a three-figure voltmeter used to detect the voltage of three-phase AC power supply.
<b>022-3</b>	The specification of this soft starter is 22KW/380V.
<b>H1:F04</b> ....	This indicates the last failure tip. F:04 indicates an input open phase occurs.
<b>H9:F00</b>	This indicates no failure.
<b>VE3.0</b>	This presents the software version of the product is Ver3.0.
<b>J000</b>	This indicates total times of successful starting.
<b>RS-00</b>	This indicates the duration of the last soft starting, regardless of success or failure.

Note: H1~H9 refer to save 9 recently occurred failure tips in a recursive way.

- If entering setting mode in none soft start/stop mode, you may get tips. Press **ENTER** , then press **▲** **▼** to read tips.
- Press Enter or Stop key in the state of help, you may exit the help mode.

## Chapter 4 Operation

### 4.1 Check before operation.

The following steps should be inspected and confirmed before the soft starter is put into operation:

- ① Be sure that the application ambient and the input power supply comply with the requirements in this manual.
- ② Be sure that the main circuit is properly wired: The input power supply must be connected to the terminals R, S and T; the output terminals U, V and W must be connected to the motor; the bypass electromagnetic contactor is installed and properly connected; the ground terminal is reliably and properly grounded.
- ③ Be sure there is no short cutting or short to ground of all terminals and electrified parts. All terminals, connectors and screws are tightly fastened.

### 4.2 Operation

Now start a trial operation after all the inspection steps in 4.1 have been done. While in trial operation, it is suggested that the motor has vacant load. If everything is OK, then perform on-load running.

Be careful to select an optimum mode of operation in accordance with specific operational requirements. See the detail below:

- The factory default setting of the product operation mode is operation panel control.
  - The value of rated power current PC should be set to the same as the one on the motor's specifications label.
  - Press **RUN** to start the motor and press **STOP** to end it.
  - Be sure the motor has a smooth running without whistler or vibration.
  - If the motor starting is not good enough, just change settings of the basic functions of P1.
  - If the motor's starting torque is not powerful enough, just change the inception voltage code P0 (indicating voltage mode enabled) or the current-limiting value code P3 (indicating current mode enabled) to raise the torque.
  - Be sure the motor rotates in the correct direction.
- Only after making sure there is no anomaly, can the motor be put into formal operation.

Notes:

- 1) If there is any anomaly of the soft starter or the motor, or there is a display of the fault code - F XX, just stop operation immediately and deal with it in accordance with the protective requirements in Chapter 6.
- 2) If the on-spot ambient temperature is lower than -10°C, please restart the machine more than 30 minutes later after it is energized and preheated.

## Chapter 5 Description of Function Parameters

### 5.1 Schedule of Function Parameters

Function Code	Function Name	Setting Range	Default Value	MEMO
P0	Inception Voltage	30~70%	30%	
P1	Period of Starting	2~60S	16	
P2	Period of Soft Stop	0~60S	00	
P3	Starting Limitation Current	50~500%	400%	
P4	Max. Working Current	50~200%	100%	
P5	Undervoltage Protection	60~90%	80%	
P6	Overvoltage Protection	100~130%	120%	
P7	Starting Modes	00: current limiting; 01: voltage ramp; 02: kick + current-limiting; 03: kick + voltage ramp; 04: current ramp; 05: voltage and current-limiting double closed loop	01	
P8	Protection Classes	00: primary; 01: light load; 02: standard; 03: heavy load; 04: advanced	04	
P9	Control Modes	00: operation panel control; 01: operation panel + external control; 02: external control; 03: external control + COM control; 04: operation panel + external + COM control; 05: operation panel + COM control; 06: COM control; 07: start/stop disabled	01	
PA	Parameter Protection	00: parameter modification disabled; 01: parameter modification enabled	01	
Pb	Programming Output	00~19 detailed in Page 24 Functional Code Pb	07	
PC	Motor Rated Current	11~1200	Set according to specifications.	
Pd	Motor Protection	00~90	00	

Notes:

- 1) Idle keys for over 2 minutes, the machine will escape from the setting state automatically.
- 2) Do not set parameters during soft start or soft stop. Set them in other states.

## Chapter 5 Description of Function Parameters

### 5.2 Detailed Description of Function Parameters

**Functional Code P0 Inception Voltage** Setting Range: 30~70% Factory Default Setting: 30%

Functional description: This function is used to set the voltage value of motor soft starter when it is being started.

Note: Voltage ramp mode is enabled; Set the code P7 to "1", the value can be modified; Set P7 to "0", the inception voltage will be 40%.

**Functional Code P1 Soft Starting Time** Setting Range: 2~60S Factory Default Setting: 16S

Functional description: This function is used to set the time spent by the motor from inception voltage to rated voltage.

Note: Voltage ramp mode is enabled; Set the code P7 to "1", the value can be modified.

**Functional Code P2 Soft Stop Time** Setting Range: 0~60S Factory Default Setting: 00

Functional description: This function is used to set the time spent by the motor from being just stopped at rated speed to full stop. Set this value to "0", there is a free stop. Note: There are two stop modes for motor soft starter: soft stop and free stop. If the machine has a one-to-multi system, then set the value to "0".

#### 1) Soft Stop

① If the code P2 is not set to "0", then soft stop mode is selected. The figure below is the output current waveform in the mode of soft stop. Under this condition, the motor is powered by a thyristor shifted from a bypass contactor to a soft starter; the output voltage of this soft starter gradually decreased from full voltage till it stops completely, thus the motor decelerates smoothly and mechanical oscillation can be avoided. The output cut-off voltage of soft stop is equal to the Inception Voltage.

② In the mode of soft stop, surf of water pump loads can be reduced or even removed, and large current impulse caused by soft stop can be reduced. The current limitation value of soft stop is a percentage reckoned on the starting current-limiting value.

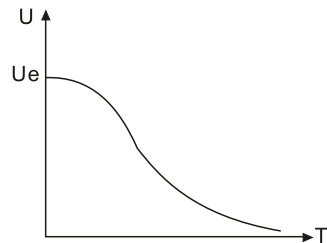

## Chapter 5 Description of Function Parameters

### 2) Free Stop

① If the code P2 is set to "0", then free stop mode is selected.

In this stop mode, once stop command is received, the soft starter will disconnect the bypass contactor and disable voltage output of the thyristor. Then the motor will gradually shutdown due to load inertia. To avoid open phase error report, P2 should be set to this mode if the soft starter adopts one-to-multi wiring method.

② To extend the service life of soft starter, free stop mode is generally preferred if there is no need to adopt soft stop mode. In free stop mode, instantaneous output is completely disabled, thus instantaneous impulse of heavy current can be avoided. ZJR1 series of soft starters provide 6 working modes applicable to various kinds of motors and loads. So users should choose a proper one according to different applications.

**Functional Code P3 Starting Limitation Current** Setting Range: 50~500% Default Setting: 400%

Functional description: This function is used to set the peak output current value of a motor soft starter when it is starting. The formula is: set value  $\times$  motor rated current (Function PC) = peak current (unit: A) that is limited by a motor soft starter to be output. Note: Current limiting mode enabled; If the code P7 is set to "0", the modification will be valid; If P7 is set to "1", the current limiting value will be 400%.

**Functional Code P4 Max. Working Current** Setting Range: 50~200% Default Setting: 100%

Functional description: Maximum working current refers to maximum current performing sustainable operation whose value is reckoned on the basis of the set value in the functional code PC. If the current exceeds the max value, there will be an inverse-time thermal relief protection.

Note: Modification will be valid if the code P7 is set to "0".

**Functional Code P5 Undervoltage Protection** Setting Range: 60~90% Default Setting: 80%

Functional description: When the actual working voltage is lower than the set value, then protection for motor soft starter is disabled and the LED display F09.

**Functional Code P6 Overvoltage Protection** Setting Range: 100~130% Default Setting: 120%

Functional description: When the actual working voltage is higher than the set value, then protection for the motor soft starter is disabled and the LED display F10.

**Functional Code P7 Starting Mode** Setting Range: 00~05 Default Setting: 01

#### 1) Current-limiting Start

① If the code P7 is set to "0" (indicating current limiting), then current starting mode is selected. The figure below is a current change waveform of a motor in the mode of current-limiting start. "I1" in the figure refers to the set value of starting current-limiting. When the motor starts, the output voltage will rise rapidly till the motor current reaches the set current-limiting value "I1" and

## Chapter 5 Description of Function Parameters

will not goup any more. Then, with gradualraise of output value, the motor will accelerate gradually. When the motorspeed reaches the rated speed of rotation, the bypass contactor will attract (kick on) and the output current will go down rapidly to the motor rated current "Ie" or below. Thus the starting process is finished.

② Even if the motor has a light load or the set value of current-limiting is big, there is still the possibility that the maximum current of the motor during start can not reach the set value of current-limiting. Current-limiting start mode is usually applied on the occasion where strict limitation of current is required.

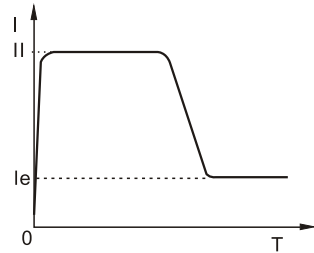

### 2) Voltage Ramp Start

① When the code P7 is set to "1" (voltage), then voltage start mode is selected. The figure below is a waveform of output voltage during voltage limiting ramp start. U1 in the figure is the starting inception voltage. When the motor is started and its current does not exceed 400% of its rated value, the output voltage of soft starter will jump up to U1, then the output voltage will rise gradually as the set starting parameter, and the motor will accelerate with voltage rise. When the voltage reaches the rated voltage Ue, the motor will run at rated rotation speed and the bypass contactor will pickup, thus the start-up procedure will be completed.

② Starting Time: T is the control parameter derived by standard load under standard experimental conditions, based on which the soft starter is able to accelerate the motor smoothly to complete starting process through the control over output voltage but not through the mechanical control over time (t) regardless of whether the motor is accelerated steadily. Therefore, if there is a light load, the starting time will tend to be less than the set starting time. It is normal if the machine can be started smoothly. Generally speaking, voltage ramp start mode is applicable to the occasion where there is no strict requirement on starting current but a high requirement on the stability of starting.

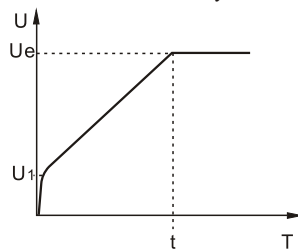

-21-

## Chapter 5 Description of Function Parameters

### 3) Kick Start

① When the code P7 is set to "2" (kick + current-limiting) or "3" (kick + voltage), then kick start mode is selected. The figure below is the change waveform of output in kick start mode. This start mode can be selected in case there is a failure start of the motor due to influence of the machine's static friction force on the occasion of heavy loads. While the machine is just started, DO feed a fixed higher voltage to the motor and keep it for a short period of time so as to smooth away static friction force of motor loads and enable the motor to rotate, and then select a start mode of current-limiting or voltage ramp.

② Before selecting this mode, it is strongly recommended to start the motor by non-kick starting. Then select this mode ONLY AFTER the motor failed to start. DO keep clear of kick start as possible to reduce unnecessary impulse of strong current.

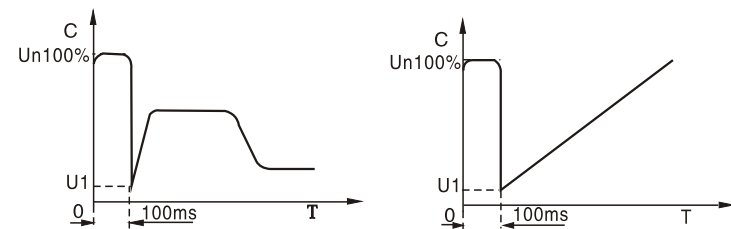

### 4) Current Ramp Start

① When the code P7 is set to "4" (current ramp), then current ramp start mode is selected. The figure below is a waveform of output current in the mode of current ramp start. "I1" in this figure stands for current-limiting value set by the code P3, and T1 stands for time set by the code P1.

② Current ramp start mode is applicable to bipolar motor owing to its strong accelerating capacity. This mode can also shorten the starting period of time within a certain range.

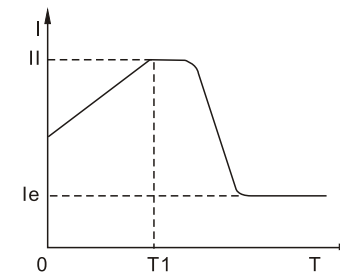

-22-

## Chapter 5 Description of Function Parameters

### 5) Voltage and Current-limiting Double-closed Loop Start

① When the code P7 is set to "5" (double closed-loop), then this start mode is selected. Voltage and current-limiting double-closed loop start mode, with adoption of voltage ramp and current-limiting double-closed loop control, is a kind of comprehensive start mode that both steady start and strict current-limiting are required. It uses a pre-reckoning method for estimating the working state of the motor.

② The waveform of output voltage in this mode always fluctuates according to different conditions of the motor and loads.

**Functional Code P8 Protective Class** Setting Range: 00~04 Factory Default Setting: 04

To adapt to different applications, this motor soft starter provides 5 protection classes, namely, 0: primary class; 1: light load; 2: standard; 3 heavy load; 4: advanced, which are set by the code P8.

Primary protection, disabling the function of external instantaneous terminals and only remaining overheat protection, shortcut protection and input open phase protection while starting, is applied to some emergency occasions, i.e., fire pump etc..

Light load, standard and heavy load protection classes have full protection functions. Their distinguish lies in different time curves of motor's overload heat protection.

Refer to the table below and the figure in page 26 to see time parameters for motor heat protection.

The protection standard for advanced protection is even stricter. Functional parameters for the rest protection classes are set the same as the standard protection. See the table below for different protection classes and heat protection set by the code P8.

P8 Setting	0 (Primary Class)	1 (Light Load)			2 (Standard)			3 (Heavy Load)			4 (Advanced)			Description
Overload Running Protection Classes	/	Class 2			Class 10			Class 20			Class 10			In accordance with IEC60947-4-2 standard.
Overcurrent Starting Protection Time	/	3S			15S			30S			15S			Based on that the starting current is more than 5 times the set value.
Overload Running Trip Time Lists	Current Multiple (I/le)	3	4	5	3	4	5	3	4	5	3	4	5	Numerical values in this table are typical ones.
	Trip Time(S)	4.5	2.3	1.5	23	12	7.5	46	23	15	23	12	7.5	

**Functional Code P9 Control Modes** Setting Range: 00~07 Factory Default Setting: 01

00: operation panel control; 01: operation panel + external control; 02: external control; 03: external control + COM control; 04: operation panel + external + COM control; 05: operation panel + COM control; 06: COM control; 07: start/stop disabled

## Chapter 5 Description of Function Parameters

**Functional Code PA Parameter Protection** Setting Range: 00~01 Factory Default Setting: 01

Functional Description: This function is used to set whether the internal parameters of the motor soft starter are allowed to be modified.

00: Parameter modification disabled; 01: Parameter modification enabled.

**Functional Code Pb Programmable Output** Setting Range: 00~19 Factory Default Setting: 07

Code Pb is used to set the action time for operation output relay.

- The output function of programmable relay provides 2 working modes: programmable sequential output and programmable status output.
- When Pb is set to 0~4 (10~14), programmable output works in the mode of time output. The set starting moment of this output is seen in the table below:

Values set by Pb	0(10)	1(11)	2(12)	3(13)	4(14)
Moment of Programmable Output	When ordering the command of start	When being started	When bypass runs	When ordering the command of stop	When shutdown is completed

● This working mode is used in an immediate state and the relay acts at the moment when the state set by Pb just begins. The reset moment of this output will be completed 1 second' s later after this state ends up. Eg.: The factory default setting value of Pb is 7, which means the soft starter is in a "hold" mode when energized and the relay attracts at the same time. If the soft starter receives start command at this moment, then the relay will be disconnected.

● Programmable sequential output mode takes the whole process of a start as its control cycle. If the motor is restarted, the previous programming output will automatically be interrupted and this procedure shall be preceded again.

● If Pb is set to 5~9, the programmable output working and state output mode, and the set working state output will be shown in the table below:

Values set by Pb	5(15)	6(16)	7(17)	8(18)	9(19)
Moment of Programmable Output	Fault State	Operation State	Hold State	Starting State	Bypass State

● Programmable state output is used to indicate the working state of soft starter. The factory default setting value of Pb is 7, which indicates hold mode of softer starter. In this state, the motor can be started. When programmable output is in fault state, it indicates motor failure (-F05, -F06, -F07, -F08, -F12), which is different from the function of failure output terminals. Operation state refers to non-hold or non-fault state, including such three procedures as start, bypass and soft stop.

● If Pb > 9, the reset state of programmable output ③ ④ external terminals) changes from open to close, that is, reversed phase output. Flexible use of programmable relay output functions can simplify external control logic circuit.

## Chapter 5 Description of Function Parameters

Functional Code PC Motor Rated Current Setting Range: 11~1200  
Factory Default Setting: Set according to the specifications

Function Description: This parameter should be set in conformity with rated current value displayed on specifications label of the motor. Otherwise, it may cause big deviation between starting current and protective current. The motor rated current set by PC should not be 20% lower than the nominal current of soft starter. The flexibility tolerance of protective trip action will increase if there is less motor rated current set by PC.

Functional Code Pd Motor Protection Setting Range: 00~90 Factory Default Setting: 00

### 1) Descriptions of Protective Functions

This motor softstarter has perfect protective functions to guarantee safety while using soft starter and motor. While in use, DO set proper protection classes and protection parameters according to different circumstances.

Soft Starter Overheat Protection: Overheat protection enabled when temperature rises to  $90 \pm 5^\circ\text{C}$  and disabled when temperature falls to  $60^\circ\text{C}$  (lowest).

Input open phase protection lag time: <3S

Output open phase protection lag time: <3S

Three-phase Unbalance Protection Time: <3S. Based on the rule that all phases of current deviation is larger than  $50 \pm 10\%$ , when load current is 30% lower than the nominal rated value of soft starter, the decision datum deviation will be enhanced.

Overcurrent Starting Protection Time: This refers to the protection time that is successively 5 times longer than the maximum working current set by the code P4. See protection Time Table in Page 23.

Overload Running Protection Time: This refers to the inverse time thermal relief protection based on the maximum working current set by the code P4. See the curve of trip protection time in the figure on page 26.

Power Supply Undervoltage Protection Lag Time: When power supply voltage is 40% lower than limit value, the protection time will be less than 0.5 second; when the power supply voltage is lower than the set value, the protection time will be less than 3 seconds.

Power Supply Overvoltage Protection Lag Time: When power supply voltage is 130% higher than limit value, the protection time will be less than 0.5 second; when the power supply voltage is higher than the set value, the protection time will be less than 3 seconds.

Load Shortcut Protection Retarding Time: <01 second. If the current is 10 times or more as nominal rated current of the soft starter, than a fuse or shortcut device shall be used.

The above time parameters are set for the period from valid signals are detected to trip protection command is given. They are for reference only.

If protective functions of this softstarter do not comply with users' needs, then special protective devices shall be used to insure safety.

## Chapter 5 Description of Function Parameters

### 2) Protective Trip Curve

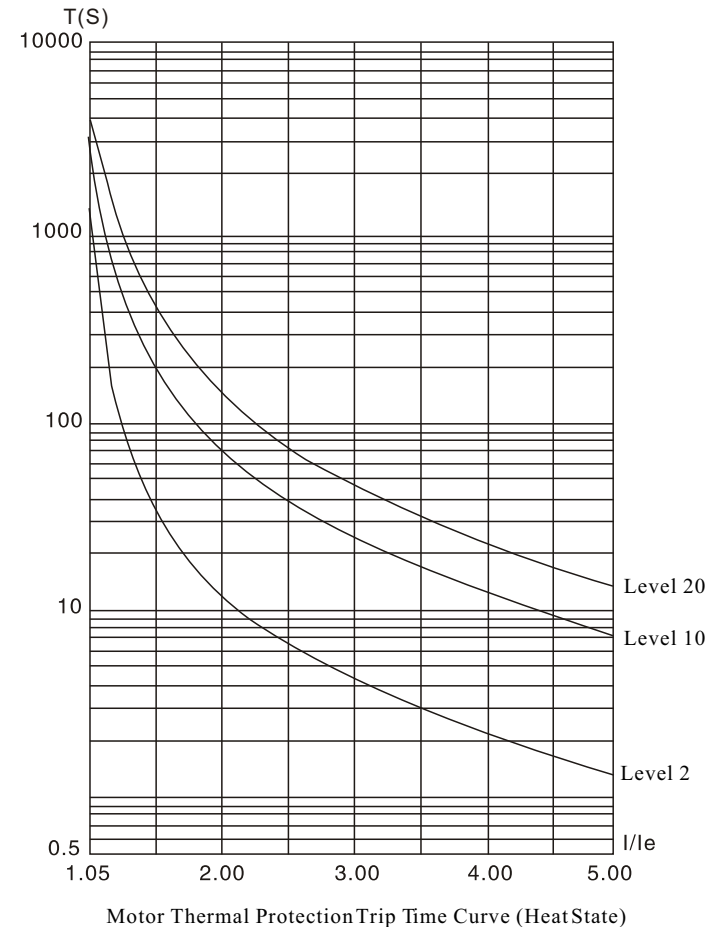

## Chapter 6 Trouble Protection & Treatment

### 6.1 Schedule of Protection Operating

Protective functions enabled with an immediate tripping once anomaly of the soft starter occurs. Refer to the descriptions below for warnings and relevant contents displayed on LED.

Panel Display	Warnings	Actions & Treatment
-F 00	Fault cleared!	Faults such as undervoltage, overvoltage, overcurrent, instantaneous terminal open etc. have been eliminated. Everything turns to normal and now the LED "ready" lights up, indicating the motor can be started after reset.
-F 01	External instantaneous terminals open	Check the connection between terminal 07 and terminal 10, or check break contacts of other protective devices.
-F 02	Soft starter overheat	Check if starting is too frequently operated or the motor power doesn't match the soft starter.
-F 03	Starting time too long	Check if starting parameters are improperly set; the load is too heavy or the power capacity is insufficient.
-F 04	Input open phase	Check if three-phase power supply is solidly connected, the bypass contactor is chucked on the closed position, the SCR is shortcut and the ground wire (G) is properly connected.
-F 05	Output open phase	Check if connecting wires of output loop and the motor is firm, the bypass contactor is chucked on the closed position, the SCR is shortcut and the ground wire (G) is properly connected.
-F 06	Three phases unbalanced	Check if there is anomaly of input three-phase power supply or the load motor.
-F 07	Starting overcurrent	Check if the load is too heavy or the motor power doesn't match the soft starter.
-F 08	Operating overload protection	Check if there is any too heavy load or improper parameter set by the code P4 and PC.
-F 09	Power supply voltage below level	Check if there is error input power supply voltage or improper parameter set by the code P5.
-F 10	Power supply voltage too high	Check if there is error input power supply voltage or improper parameter set by the code P6.
-F 11	Parameter setting error	Modify settings or press  to restore to the default settings of soft starter when it is energized.
-F 12	Load shortcut	Check the load or the motor; check if the SCR is shortcut or over loaded.
-F 13	Auto restart wiring error	Check the external control start and stop terminals if they are in two-wire control mode.
-F 14	External control stop terminal wiring error	When external control mode is enabled, external control stop terminals will open, which lead to failure start of the motor.

Notes:

- 1) Some faults are correlative, i.e., if there is a report of F02 (soft starter overheat), this may be concerned with starting overcurrent or load shortcut. Therefore, full considerations should be taken to have an exact judge on faults during troubleshooting.
- 2) When the soft starter starts the motor, the operation LED in the middle of the panel lights up, which indicates the machine is in the state of bypass operation. If bypass contactor fails to pickup at this time, which results in stop of the motor, check if there is any error or bad contact of the bypass contactor and relevant connecting wires.
- 3) If any protective action occurs, press STOP/RESET key to remove failure state after troubleshooting, then restart the machine.

## Chapter 6 Trouble Protection & Treatment

### 6.2 Trouble Diagnosis and Troubleshooting

Anomalies	Items to Check	Solutions
The motor can't rotate.	Check if there is abnormal wiring. Be sure that power lines are connected to input terminals (R, S, T).	Perform correct wiring. Cut off power supply and then perform rewiring.
	Check if bypass contactor works. Be sure terminals 01, 02 have signals.	Check the connection of bypass contactor. Check the control and connection of the coil loop of bypass contactor.
	Check if there is abnormal display on the operation panel.	Refer to page 27 "Schedule of Protection Operating".
	Check if the motor is locked or there is too heavy load.	Unlock the motor or lighten the loads.
Keyboard starting is disabled.	Check if there is error tip on the operation panel. Be sure that the terminals 07, 10 are open and settings of the code P9 is correct.	If no error tip is displayed, check the input power supply. If error tip is displayed, check if the terminals 07, 08 and 10 are open; check external wiring of the terminals and set parameters of P9 properly.
External control starting is disabled.	Check if the code P9 is set to external control.	If open circuits occur among the terminals 07, 08 and 10, check external wiring of terminals; set parameters of P9 properly. Be sure external control has been set.
The motor rotates but its speed cannot be raised.	Check if there is too heavy load.	Lighten the loads. Modify parameters; increase the inception voltage or starting current.
Starting time is too long.	Check if there is too heavy load. Be sure parameter settings of the soft starter are proper and the motor model is correct.	Lighten the loads. Set P0 (inception voltage), P3 (starting limitation current) and P1 (soft start time) properly. Check model descriptions of soft starter and its specifications label.
Starting time is too short.	Check if there is light load or too short starting time.	When there is a light load, the starting time is generally shorter than the set value. It will be normal if there is a balanced start. Set the starting time of P1. (current mode invalid)
Sudden shutdown occurs during operation.	Check external input terminals.	Check if there is any loosen connection between the terminal 07 and 10. If there is an external protector, check if the break contact works. Check if there is loosen connecting wire of external stop button.

## Chapter 7 Structure and Sizes

### 7.1 Outline Sizes & Install Sizes

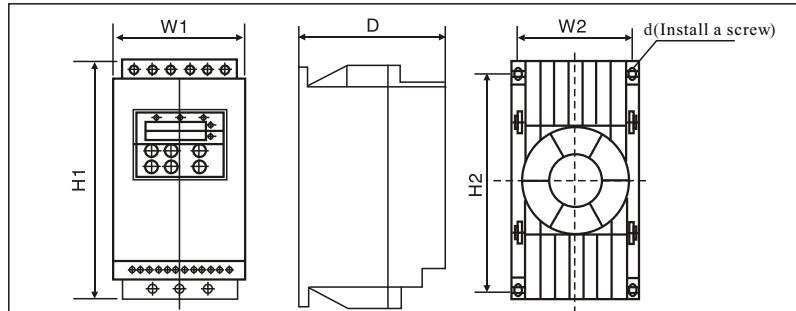

Models	Rated Power(KW)	Rated Current(A)	Outline Sizes			Install Sizes			Net Weight (Kg)
			H1	W1	D	H2	W2	d	
ZJR1-3055	5.5	11	270	145	159	245	130	M6	<3.5
ZJR1-3075	7.5	15	270	145	159	245	130	M6	<3.5
ZJR1-3110	11	22	270	145	159	245	130	M6	<3.5
ZJR1-3150	15	30	270	145	159	245	130	M6	<3.5
ZJR1-3185	18.5	37	270	145	159	245	130	M6	<3.5
ZJR1-3220	22	44	270	145	159	245	130	M6	<3.5
ZJR1-3300	30	60	270	145	159	245	130	M6	<3.5
ZJR1-3370	37	75	270	145	159	245	130	M6	<3.5
ZJR1-3450	45	90	270	145	159	245	130	M6	<3.5
ZJR1-3550	55	110	270	145	159	245	130	M6	<3.5

Notes:  
 The rated power and rated current in the table above are the maximum values of a soft starter. Generally, rated current matching the motor that has same power should not exceed the rated current values listed in this table.  
 If outline sizes differ from the values above, please refer to actual sizes.

## Chapter 7 Structure and Sizes

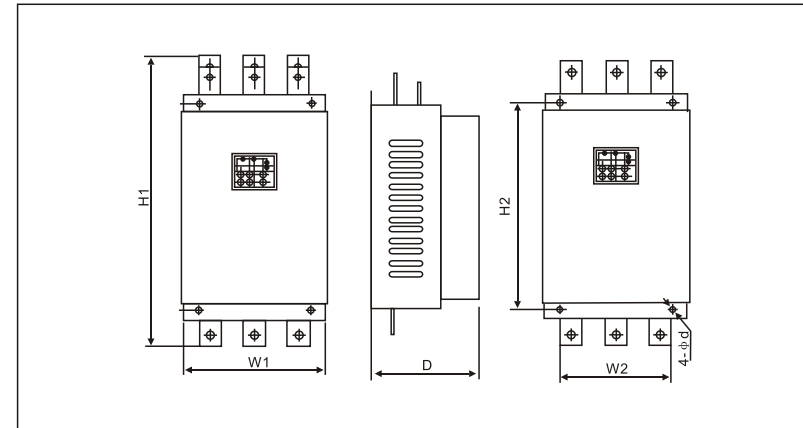

Models	Rated Power(KW)	Rated Current(A)	Outline Sizes			Install Sizes			Net Weight (Kg)
			H1	W1	D	H2	W2	d	
ZJR1-3750	75	150	530	260	202	380	196	M8	< 25
ZJR1-3900	90	180	530	260	202	380	196	M8	< 25
ZJR1-31100	110	220	530	260	202	380	196	M8	< 25
ZJR1-31300	132	264	530	260	202	380	196	M8	< 25
ZJR1-31600	160	320	530	260	202	380	196	M8	< 25
ZJR1-32000	200	400	530	260	202	380	196	M8	< 25
ZJR1-32500	250	500	580	290	245	460	260	M8	< 35
ZJR1-32800	280	560	580	290	245	460	260	M8	< 35
ZJR1-33150	315	630	580	290	245	460	260	M8	< 35
ZJR1-34000	400	800	Made to Order					M8	< 40
ZJR1-35000	500	1000						M8	< 45

Notes:  
 The rated power and rated current in the table above are the maximum values of a soft starter. Generally, rated current matching the motor that has same power should not exceed the rated current values listed in this table.  
 If outline sizes differ from the values above, please refer to actual sizes.

## Chapter 8 Quality Warranty

### 1) Warranty Period Under Normal Conditions

① We provide guarantees for repair, replacement and return of the purchase in 1 month from the date of use.

② We provide guarantees for repair and replacement in 3 months from the date of use.

③ We provide guarantee for repair in 12 months from the date of use or 18 months from the date of ex-factory.

2) The purchaser enjoys life-long paid service whenever and wherever he uses a motor soft starter made in our company.

3) Service in the following cases, even within the warranty period, shall be charged to the purchaser:

① Problems caused by mal-operation in violation of this manual, or caused by unauthorized repair or renovation.

② Problems caused by improper use of soft starter that is off standard and requirement;

③ Malfunction or damage caused by improper transit or storage after purchase;

④ Induced failure or aging of the device due to poor ambient;

⑤ Malfunction or damage caused by fire, flood, thunder, earthquake, abnormal voltage or other natural disasters;

⑥ Unidentifiable nameplate, mark and ORD number due to intentional spoilage;

⑦ Delayed or unsatisfied payment in violation of purchase appointment;

⑧ Fail to give an objective description on the use of installation, wiring, operation, maintenance or else;

4) Defective products should be sent to us for repair, replacement and return, which can be proceeded only after verifying the burden of liability.

5) In case there is any quality problem or accident, we merely promise to bear the above-mentioned responsibilities. If a user needs more guarantees for liabilities, please assure on the insurance company voluntarily.

## Appendix

### 1) Varieties of Application Loads

This soft start can meet the requirements of most heavy loads. The table below is for reference only.

Varieties of Application Loads	Start Ramp Time (S)	Stop Ramp Time (S)	Inception Voltage (%)	Voltage Start (Maximum Current-limiting Value)	Current-limiting Start
Centrifugal Pump	16	20	40	4	2.5
Ball Grinder	20	6	60	4	3.5
Fan	26	4	30	4	3.5
Piston Type Compressor	16	4	40	4	3
Light Load Motor	16	2	30	4	3
Elevating Mechanism	6	10	60	4	3.5
Mixer	16	2	50	4	3
Crusher	16	10	50	4	3.5
Screw Compressor	16	2	40	4	3
Spiral Conveyor	20	10	40	4	2
Leather Belt Conveyor	20	10	40	4	2.5
Heat Pump	16	20	40	4	3

### 2) RS485 Communication

This soft starter can be connected to PC, PLC or other hosts through a built-in RS485 standard interface to perform serial communication (COM). The host can give a command to start or stop the soft starter, monitor the operation state of the soft starter and modify its functional parameters. For details of this communication, please refer to RS485 Operating Manual. By using RS485 COM of the soft starter, remote operation can be realized via a computer such as input of run command, management on operation state, and one-step writing of functional codes for multiple soft starters to realize simplified operation while inputting functional codes.

#### Main Functions of RS485 COM:

① Inputting start or stop command;

② Monitoring operation status;

③ Real-time tracing (i.e., table display of running information);

④ Once-step reading and writing of functional codes, and saving to the file;

A separate agreement shall be signed between the two parties of us for communication software.